



Glavno

Serijska izdelka	Modicon X80
Izdelek ali sestavni del	Analogni vhodni modul
Električna povezava	28 smerni 1 konektor
Isolation between channels	Izolacijski
Vhodna raven	Visoka raven
Številka analognega vhoda	8
Tip analognega vhoda	Tok +/- 20 mA Tok 0 do 20 mA Tok 4 do 20 mA Napetost +/- 10 V Napetost +/- 5 V Napetost 0 do 10 V Napetost 0 do 5 V Napetost 1 do 5 V

Komplementarno

Analogna/digitalna konverzija	16 bitov
Ločljivost analognega vhoda	15 bitov + znak
Dovoljena preobremenitev na vhodih	+/- 30 mA 0 do 20 mA +/- 30 mA 4 do 20 mA +/- 30 V +/- 10 V +/- 30 V +/- 5 V +/- 30 V 0 do 10 V +/- 30 V 0 do 5 V +/- 30 V 1 do 5 V +/- 30 mA +/- 20 mA
Vhodna impedanca	10 MOhm in voltage mode 250 Ohm + 3.6...50 Ohm internal protective resistor in current mode
Natančnost notranjega pretvornega upora	0,1 % - 15 ppm/°C
Tip filtra	Digitalno filtriranje prvega reda
Hiter cikel branja	1 ms + 1 ms x število uporabljenih kanalov
Nazivni čas branja cikla	9 ms za 8 kanalov
Merilna napaka	<= 0.1 % of full scale +/- 10 V 0...60 °C <= 0.1 % of full scale +/- 5 V 0...60 °C <= 0.1 % of full scale 0...10 V 0...60 °C <= 0.1 % of full scale 0...5 V 0...60 °C <= 0.1 % of full scale 1...5 V 0...60 °C <= 0.3 % of full scale +/- 20 mA 0...60 °C <= 0.3 % of full scale 0...20 mA 0...60 °C <= 0.3 % of full scale 4...20 mA 0...60 °C 0.15 % of full scale +/- 20 mA 25 °C 0.15 % of full scale 0...20 mA 25 °C 0.15 % of full scale 4...20 mA 25 °C 0.075 % of full scale +/- 10 V 25 °C 0.075 % of full scale 0...10 V 25 °C 0.075 % of full scale 0...5 V 25 °C 0.075 % of full scale 1...5 V 25 °C 0.075 % of full scale +/- 5 V 25 °C

The information provided in this documentation contains general descriptions and/or technical characteristics of the performance of the products contained herein. This documentation is not intended as a substitute for and is not to be used for determining suitability or reliability of these products for specific user applications. It is the duty of any such user or integrator to perform the appropriate and complete risk analysis, evaluation and testing of the products with respect to the relevant specific application or use thereof. Neither Schneider Electric Industries SAS nor any of its affiliates or subsidiaries shall be responsible or liable for misuse of the information contained herein.

Temperature drift	30 ppm/°C +/- 10 V 30 ppm/°C +/- 5 V 30 ppm/°C 0...10 V 30 ppm/°C 0...5 V 30 ppm/°C 1...5 V 50 ppm/°C +/- 20 mA 50 ppm/°C 0...20 mA 50 ppm/°C 4...20 mA
Min. "crosstalk" atenuacija	80 DB
Odpravljanje EMI/RFI motenj (100 kHz do 10 MHz)	80&Nbsp;DB
Format digitalne vrednosti	- 32768 to + 32767 in maximum user scale +/- 10000 privzeto
Izolacijska napetost	300 V DC Med kanali 1400 V DC Med kanali in ozemljitvijo 1400 V DC Med kanali in vodilom
Merjenje ločljivosti	0,36 mV +/- 10 V 0,36 mV 0 do 10 V 0,36 mV 0 do 5 V 0,36 mV 1 do 5 V 0,36 mV +/- 5 V 1,4 µA +/- 20 mA 1,4 µA 0 do 20 mA 1,4 µA 4 do 20 mA
Maksimalna vrednost konverzije	+/- 11.4 V +/- 10 V +/- 11.4 V 0...10 V +/- 11.4 V 0...5 V +/- 11.4 V 1...5 V 0...30 mA +/- 20 mA 0...30 mA 0...20 mA 0...30 mA 4...20 mA 0...30 mA +/- 5 V
Nadmorska višina delovanja	0 do 2000 m 2000 do 5000 m Z redukcijskim faktorjem
Status LED	1 LED (Zelena) RUN 1 LED na kanal (Zelena) Diagnostika kanala 1 LED (Rdeča) ERR 1 LED (Rdeča) I/O
Teža izdelka	0,165 Kg
Poraba energije v W	1,06 W 24 V DC Tipičen 1,50 W 24 V DC Maksimum 0,32 W 3,3 V DC Tipičen 0,48 W 3,3 V DC Maksimum

Okolje

Odpornost proti vibracijam	3 Gn
Odporno proti udarcu	30 Gn
Temperatura okoliškega zraka za skladiščenje	-40...85 °C
Temperatura okoliškega zraka za delovanje	0...60 °C
Relativna vlažnost	5...95 % 55 °C Brez kondenzacije
IP stopnja zaščite	IP20
Direktive	2014/35/EU - direktiva nizke napetosti 2014/30/EU - elektromagnetna kompatibilnost
Certifikati izdelkov	CE RCM CSA EAC Merchant Navy UL
Standardi	EN/IEC 61010-2-201 EN/IEC 61131-2 UL 61010-2-201 CSA C22.2 št. 61010-2-201

Embalažna enota

Unit Type of Package 1	PCE
Number of Units in Package 1	1
Package 1 Height	5,5 Cm
Package 1 Width	11,0 Cm
Package 1 Length	11,5 Cm
Package 1 Weight	160,0 G
Unit Type of Package 2	S02
Number of Units in Package 2	15
Package 2 Height	15,0 Cm
Package 2 Width	30,0 Cm
Package 2 Length	40,0 Cm
Package 2 Weight	2,668 Kg

Trajnost ponudbe

Status trajnostne ponudbe	Izdelek Green Premium
Uredba REACH	Izjava REACH
REACH, brez snovi SVHC	Da
Direktiva EU ROHS	Proaktivno zagotavljanje skladnosti (izdelek je zunaj področja uporabe direktive EU RoHS) Izjava EU RoHS
Brez živega srebra	Da
Informacije o izvzetju iz RoHS	Da
Uredba o RoHS za Kitajsko	Izjava O RoHS Za Kitajsko
Razkritje okoljskih podatkov	Okoljski Profil Izdelka
Profil krožnega gospodarstva	Informacije O Izteku Življenjske Dobe
OEE0	Na trgih Evropske unije je treba izdelek zavreči v skladu s posebnim postopkom zbiranja odpadkov in ga ni dovoljeno zavreči skupaj z gospodinjskimi odpadki.

Pogodbena garancija

Garancija	18 months
-----------	-----------

Modules Mounted on Racks

Dimensions

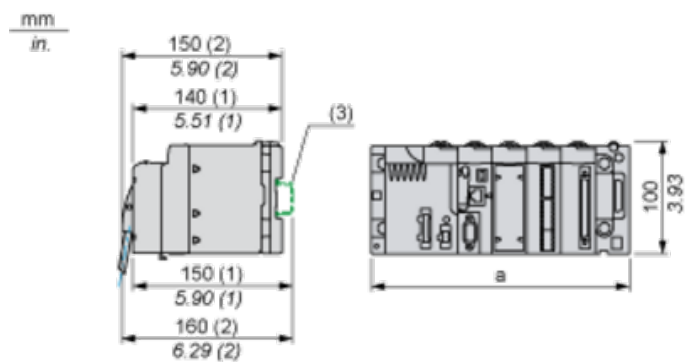

(1) With removable terminal block (cage, screw or spring).

(2) With FCN connector.

(3) On AM1 ED rail: 35 mm wide, 15 mm deep. Only possible with BMXXBP0400/0400H/0600/0600H/0800/0800H rack.

Rack references	a in mm	a in in.
BMXXBP0400 and BMXXBP0400H	242.4	09.54
BMXXBP0600 and BMXXBP0600H	307.6	12.11
BMXXBP0800 and BMXXBP0800H	372.8	14.68
BMXXBP1200 and BMXXBP1200H	503.2	19.81

Wiring Diagram

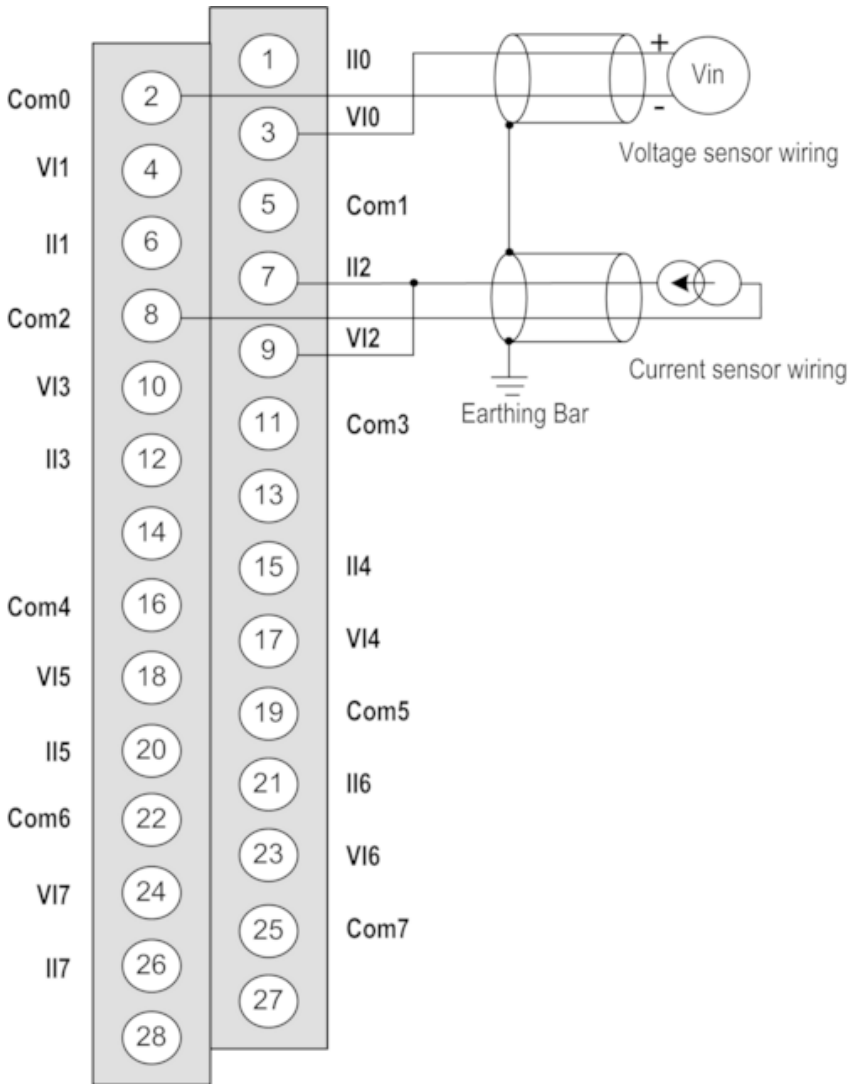

VIx + pole input for channel x
 COM x - pole input for channel x
 IIx current reading resistor + input
 Channel 0 voltage sensor
 Channel 1 2-wire current sensor