

# BMXART0814

## Modul analognega vhoda M340 - 8 temperaturnih vhodov



### Glavno

Serijska izdelka	Modicon X80
Izdelek ali sestavni del	Analogni vhodni modul
Električna povezava	40 smeri 2 konektorja
Isolation between channels	Izolacijski
Vhodna raven	Nizka raven
Številka analognega vhoda	8
Tip analognega vhoda	<p>Napetost +/- 1,28 V</p> <p>Napetost +/- 160 mV</p> <p>Napetost +/- 320 mV</p> <p>Napetost +/- 40 mV</p> <p>Napetost +/- 640 mV</p> <p>Napetost +/- 80 mV</p> <p>Upor 400 Ohm 2 žici</p> <p>Upor 400 Ohm 3 žice</p> <p>Upor 400 Ohm 4 žice</p> <p>Upor 4000 Ohm 2 žici</p> <p>Upor 4000 Ohm 3 žice</p> <p>Upor 4000 Ohm 4 žice</p> <p>Temperaturna sonda -100 do +260 °C Cu 10</p> <p>Temperaturna sonda -100 do +450 °C Pt 100 UL/JIS</p> <p>Temperaturna sonda -100 do +450 °C Pt 1000 UL/JIS</p> <p>Temperaturna sonda -200 do +850 °C Pt 100 IEC</p> <p>Temperaturna sonda -200 do +850 °C Pt 1000 IEC</p> <p>Temperaturna sonda -60 do +180 °C Ni 100</p> <p>Temperaturna sonda -60 do +180 °C Ni 1000</p> <p>Termočlen +130 do +1820 °C Termočlen B</p> <p>Termočlen +270 do +1300 °C Termočlen N</p> <p>Termočlen -200 do +600 °C Termočlen U</p> <p>Termočlen -200 do +760 °C Termočlen J</p> <p>Termočlen -200 do +900 °C Termočlen L</p> <p>Termočlen -270 do +1000 °C Termočlen E</p> <p>Termočlen -270 do +1370 °C Termočlen K</p> <p>Termočlen -270 do +400 °C Termočlen T</p> <p>Termočlen -50 do +1769 °C Termočlen R</p> <p>Termočlen -50 do +1769 °C Termočlen S</p>

### Komplementarno

Analogna/digitalna konverzija	Sigma delta 16 bitov
Ločljivost analognega vhoda	15 bitov + znak
Dovoljena preobremenitev na vhodih	<p>+/- 7,5 V +/- 1,28 V</p> <p>+/- 7,5 V +/- 160 mV</p> <p>+/- 7,5 V +/- 320 mV</p> <p>+/- 7,5 V +/- 40 mV</p> <p>+/- 7,5 V +/- 640 mV</p> <p>+/- 7,5 V +/- 80 mV</p>
Skupni način zavrnitve	120 dB 50/60 Hz
Zavrnitev diferencialnega načina	60 DB 50/60 Hz
Kompensacija hladnega spoja	Zunanji z Pt100 sondo
Tip filtra	Digitalno filtriranje prvega reda
Nazivni čas branja cikla	<p>400 ms s temperaturno sondo</p> <p>200 ms s termočlenom</p>

The information provided in this documentation contains general descriptions and/or technical characteristics of the performance of the products contained herein. This documentation is not intended as a substitute for and is not to be used for determining suitability or reliability of these products for specific user applications. It is the duty of any such user or integrator to perform the appropriate and complete risk analysis, evaluation and testing of the products with respect to the relevant specific application or use thereof. Neither Schneider Electric Industries SAS nor any of its affiliates or subsidiaries shall be responsible or liable for misuse of the information contained herein.

Merilna napaka	+/- 0.7 °C Ni 1000 25 °C +/- 2 °C Pt 100 0...60 °C +/- 2 °C Pt 1000 0...60 °C +/- 2.1 °C Ni 100 25 °C +/- 2.1 °C Pt 100 25 °C +/- 2.1 °C Pt 1000 25 °C +/- 2.7 °C thermocouple U 25 °C +/- 2.8 °C thermocouple J 25 °C +/- 3 °C Ni 100 0...60 °C +/- 3 °C thermocouple L 25 °C +/- 3.2 °C thermocouple R 25 °C +/- 3.2 °C thermocouple S 25 °C +/- 3.5 °C thermocouple B 25 °C +/- 3.7 °C thermocouple E 25 °C +/- 3.7 °C thermocouple K 25 °C +/- 3.7 °C thermocouple N 25 °C +/- 3.7 °C thermocouple T 25 °C +/- 4 °C Cu 10 0...60 °C +/- 4 °C Cu 10 25 °C +/- 4.5 °C thermocouple J 0...60 °C +/- 4.5 °C thermocouple L 0...60 °C +/- 4.5 °C thermocouple R 0...60 °C +/- 4.5 °C thermocouple S 0...60 °C +/- 4.5 °C thermocouple U 0...60 °C +/- 5 °C thermocouple B 0...60 °C +/- 5 °C thermocouple E 0...60 °C +/- 5 °C thermocouple K 0...60 °C +/- 5 °C thermocouple N 0...60 °C +/- 5 °C thermocouple T 0...60 °C <= 0.15 % of full scale +/- 1.28 V 0...60 °C <= 0.15 % of full scale +/- 160 mV 0...60 °C <= 0.15 % of full scale +/- 320 mV 0...60 °C <= 0.15 % of full scale +/- 640 mV 0...60 °C <= 0.15 % of full scale +/- 80 mV 0...60 °C <= 0.2 % of full scale 4000 Ohm 0...60 °C 0.05 % of full scale +/- 1.28 V 25 °C 0.05 % of full scale +/- 160 mV 25 °C 0.05 % of full scale +/- 320 mV 25 °C 0.05 % of full scale +/- 40 mV 25 °C 0.05 % of full scale +/- 640 mV 25 °C 0.05 % of full scale +/- 80 mV 25 °C 0.12 % of full scale 400 Ohm 25 °C 0.12 % of full scale 4000 Ohm 25 °C <= 0.2 % of full scale +/- 40 mV 0...60 °C <= 0.3 % of full scale 400 Ohm 0...60 °C 1.3 °C Ni 1000 0...60 °C
Temperature drift	25 ppm/°C 400 Ohm 25 ppm/°C 4000 Ohm 25 ppm/°C Ni 1000 25 ppm/°C thermocouple B 25 ppm/°C thermocouple E 25 ppm/°C thermocouple J 25 ppm/°C thermocouple K 25 ppm/°C thermocouple L 25 ppm/°C thermocouple N 25 ppm/°C thermocouple R 25 ppm/°C thermocouple S 25 ppm/°C thermocouple T 25 ppm/°C thermocouple U 30 ppm/°C +/- 1.28 V 30 ppm/°C +/- 160 mV 30 ppm/°C +/- 320 mV 30 ppm/°C +/- 40 mV 30 ppm/°C +/- 640 mV 30 ppm/°C +/- 80 mV 30 ppm/°C Cu 10 30 ppm/°C Ni 100 30 ppm/°C Pt 100 30 ppm/°C Pt 1000
Ponovna kalibracija	Notranji

Tip zaznavanja	Odprt tokokrog Cu 10 Odprt tokokrog Ni 100 Odprt tokokrog Ni 1000 Odprt tokokrog Pt 100 Odprt tokokrog Pt 1000 Odprt tokokrog Termočlen B Odprt tokokrog Termočlen E Odprt tokokrog Termočlen J Odprt tokokrog Termočlen K Odprt tokokrog Termočlen L Odprt tokokrog Termočlen N Odprt tokokrog Termočlen R Odprt tokokrog Termočlen S Odprt tokokrog Termočlen T Odprt tokokrog Termočlen U
Maksimalna ožična odpornost	20 Ohm 2 žici Cu 10 20 Ohm 2 žici Ni 100 20 Ohm 2 žici Pt 100 20 Ohm 3 žice Cu 10 20 Ohm 3 žice Ni 100 20 Ohm 3 žice Pt 100 200 Ohm 2 žici Ni 1000 200 Ohm 2 žici Pt 1000 200 Ohm 3 žice Ni 1000 200 Ohm 3 žice Pt 1000 50 Ohm 4 žice Cu 10 50 Ohm 4 žice Ni 100 50 Ohm 4 žice Pt 100 500 Ohm 4 žice Ni 1000 500 Ohm 4 žice Pt 1000
Merjenje ločljivosti	0,1 °C Cu 10 0,1 °C Ni 100 0,1 °C Ni 1000 0,1 °C Pt 100 0,1 °C Pt 1000 0,1 °C Termočlen B 0,1 °C Termočlen E 0,1 °C Termočlen J 0,1 °C Termočlen K 0,1 °C Termočlen L 0,1 °C Termočlen N 0,1 °C Termočlen R 0,1 °C Termočlen S 0,1 °C Termočlen T 0,1 °C Termočlen U 1280/2exp14 mV +/- 1,28 V 160/2exp14 mV +/- 160 mV 320/2exp14 mV +/- 320 mV 40/2exp14 mV +/- 40 mV 12.5 mOhm 400 Ohm 125 mOhm 4000 Ohm 640/2exp14 mV +/- 640 mV 80/2exp14 mV +/- 80 mV
Maksimalna vrednost konverzije	+/- 100 % 400 Ohm +/- 100 % 4000 Ohm +/- 102.5 % +/- 1.28 V +/- 102.5 % +/- 160 mV +/- 102.5 % +/- 320 mV +/- 102.5 % +/- 40 mV +/- 102.5 % +/- 640 mV +/- 102.5 % +/- 80 mV
Nadmorska višina delovanja	0 do 2000 m 2000 do 5000 m Z redukcijskim faktorjem
Status LED	1 LED (Zelena) RUN 1 LED na kanal (Zelena) Diagnostika kanala 1 LED (Rdeča) ERR 1 LED (Rdeča) I/O
Teža izdelka	0,165 Kg
Poraba toka	150 mA 3,3 V DC

## Okolje

Odpornost proti vibracijam	3 Gn
Odporno proti udarcu	30 Gn
Temperatura okoliškega zraka za skladiščenje	-40...85 °C
Temperatura okoliškega zraka za delovanje	0...60 °C
Relativna vlažnost	5...95 % 55 °C Brez kondenzacije
IP stopnja zaščite	IP20
Direktive	2014/35/EU - direktiva nizke napetosti 2014/30/EU - elektromagnetna kompatibilnost
Certifikati izdelkov	CE EAC UL CSA Merchant Navy RCM
Standardi	EN 61131-2 EN 61000-6-4 EN 61000-6-2 EN 61010-2-201
Okoljske značilnosti	3C3 EN/IEC 60721-3-3 3C4 EN/IEC 60721-3-3

## Embalažna enota

Unit Type of Package 1	PCE
Number of Units in Package 1	1
Package 1 Height	5,4 Cm
Package 1 Width	11,0 Cm
Package 1 Length	11,7 Cm
Package 1 Weight	210,0 G
Unit Type of Package 2	S02
Number of Units in Package 2	15
Package 2 Height	15,0 Cm
Package 2 Width	30,0 Cm
Package 2 Length	40,0 Cm
Package 2 Weight	3,42 Kg

## Trajnost ponudbe

Status trajnostne ponudbe	Izdelek Green Premium
Uredba REACH	<a href="#">Izjava REACH</a>
REACH, brez snovi SVHC	Da
Direktiva EU ROHS	Proaktivno zagotavljanje skladnosti (izdelek je zunaj področja uporabe direktive EU RoHS) <a href="#">Izjava EU RoHS</a>
Brez živega srebra	Da
Informacije o izvzetju iz RoHS	<a href="#">Da</a>
Uredba o RoHS za Kitajsko	<a href="#">Izjava O RoHS Za Kitajsko</a>
Razkritje okoljskih podatkov	<a href="#">Okoljski Profil Izdelka</a>
Profil krožnega gospodarstva	<a href="#">Informacije O Izteku Življenjske Dobe</a>
OEE0	Na trgih Evropske unije je treba izdelek zavreči v skladu s posebnim postopkom zbiranja odpadkov in ga ni dovoljeno zavreči skupaj z gospodinjskimi odpadki.

## Pogodbena garancija

Garancija	18 months
-----------	-----------

Modules Mounted on Racks

Dimensions

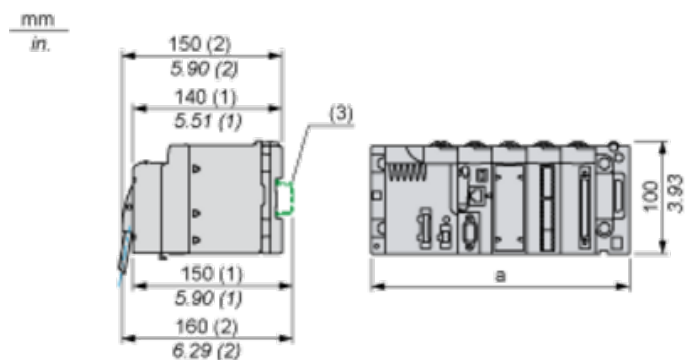

(1) With removable terminal block (cage, screw or spring).

(2) With FCN connector.

(3) On AM1 ED rail: 35 mm wide, 15 mm deep. Only possible with BMXXBP0400/0400H/0600/0600H/0800/0800H rack.

Rack references	a in mm	a in in.
BMXXBP0400 and BMXXBP0400H	242.4	09.54
BMXXBP0600 and BMXXBP0600H	307.6	12.11
BMXXBP0800 and BMXXBP0800H	372.8	14.68
BMXXBP1200 and BMXXBP1200H	503.2	19.81

Connections and Schema

Below example shows a probe configuration with:

- Channel 0/4: Thermocouple
- Channel 1/5: 2-wires RTD
- Channel 2/6: 3-wires RTD
- Channel 3/7: 4-wires RTD

Module Front View - cabling view

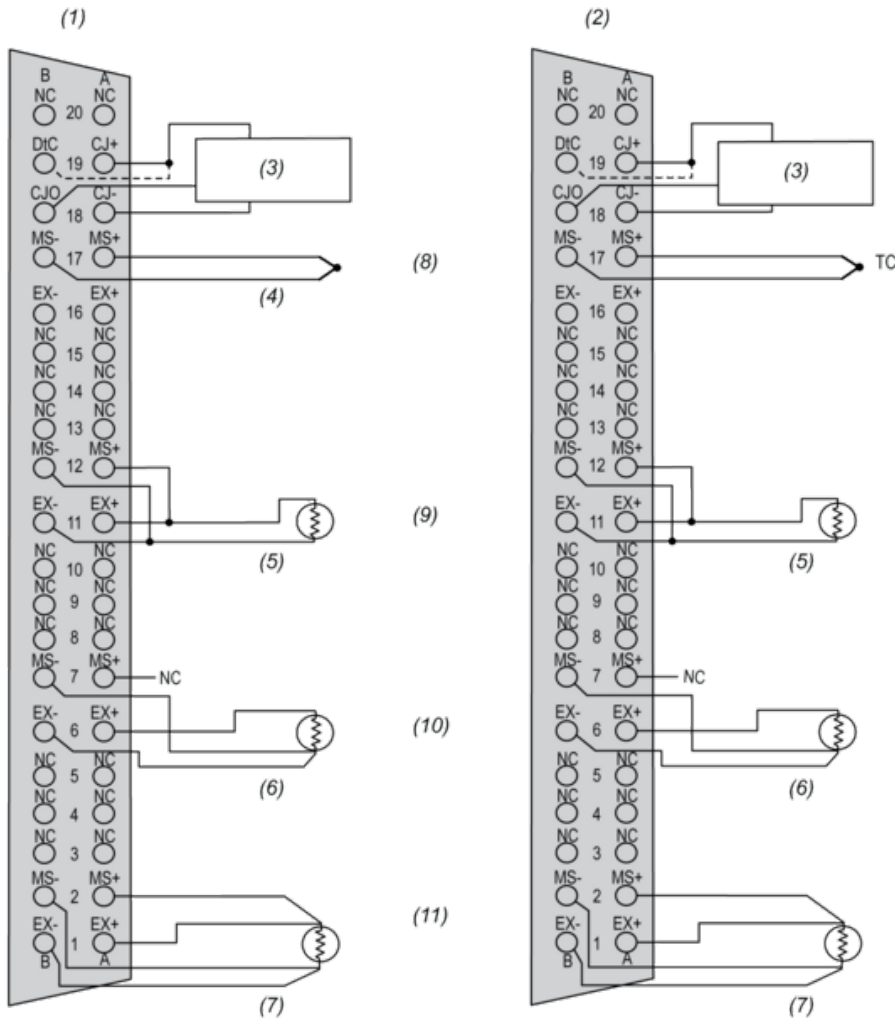

- (1) Left connector
- (2) Right connector (BMX ART 414 only)
- (3) Cold Junction temperature sensor
- (4) Thermocouple
- (5) 2-wire RTD probe
- (6) 3-wire RTD probe
- (7) 4-wire RTD probe
- (8) Channel 4/0
- (9) Channel 5/1
- (10) Channel 6/2
- (11) Channel 7/3

MS+ RTD Measure + input / Thermocouple + input  
 MS- RTD Measure - input / Thermocouple - input  
 EX+ RTD probe current generator + output

EX- RTD probe current generator - output

NC Not connected

DtC The CJC sensor detection input is connected to CJ+ if the sensor type is DS600. It is not connected (NC) if the sensor type is LM31.

NOTE: The CJC sensor is needed for TC only.