

Product data sheet
Characteristics

XMLR2D5G1P25

Tlačni senzor XMLR 2,5 bara - G 1/4 - 24 V DC
- 4 do 20 mA - PNP - M12



Glavno

Serijska izdelka	Telemecanique Pressure sensors XM
Izdelek ali sestavni del	Elektronski senzorji za pritisk
Tip senzorja tlaka	Tlačni oddajnik
Tip tlačnega stikala za operacijo	Tlačni oddajnik z 1 preklopnim izhodom
Kratko ime naprave	XMLR
Velikost senzorja tlaka	250 KPa 2,5 Bar 248,21 KPa
Maksimalni dovoljeni nenamerni tlak	1199,69 KPa 12 Bar 1200 KPa
Uničevalni tlak	12 Bar 1199,69 KPa 1200 KPa
Nadzorovana tekočina	Sveža voda 0...80 °C) Zrak -20...80 °C) Hidravlično olje -20...80 °C) Hladilna tekočina -20...80 °C)
Vrsta priključne tekočine	G 1/4 (ženski) DIN 3852-Y
[Us] Nazivna napajalna napetost	24 V DC SELV 17...33 V)

Komplementarno

Poraba toka	<= 50 mA
Električna povezava	Moški konektor M12, 4 zatiči
Funkcija analognega izhoda	4 do 20 mA
Tip izhodnega signala	Analogni + diskretni
Funkcija analognega izhoda	4 do 20 mA
Diskretni izhod tip	Polprevodniški PNP, NO/NC programabilna
Maksimalen preklopni tok	250 MA
Tip kontakta in sestava	NO/NC programabilna
Vrsta lestvice	Pritrjen diferencial
Maksimalen padec napetosti	2 V
Nastavljiv razpon preklopne točke na naraščajočem tlaku	20...250 KPa 19,99...249,59 KPa 0,2...2,5 Bar
Nastavljivo območje preklopne točke pri padajočem tlaku	13...242 KPa 0,13...2,42 Bar 12,48...242,70 KPa
Minimum differential travel	0,08 Bar 7,58 KPa 8 KPa
Materiali v stiku s tekočino	Keramika FKM fluorogljika (Viton) 316L nerjaveče jeklo
Prednji material	Poliester
Material ohišja	Poliakrilamid 316L nerjaveče jeklo
Operativni položaj	Katerikoli položaj, Vendar odtujitve lahko ponarejajo meritev v primeru montaže na glavo

The information provided in this documentation contains general descriptions and/or technical characteristics of the products contained herein. This documentation is not intended as a substitute for and is not to be used for determining suitability or reliability of these products for specific user applications. It is the duty of any such user or integrator to perform the appropriate and complete risk analysis, evaluation and testing of the products with respect to the relevant specific application or use thereof. Neither Schneider Electric Industries SAS nor any of its affiliates or subsidiaries shall be responsible or liable for misuse of the information contained herein.

Tip zaščite	Zaščita kratkega stika Prenapetostna zaščita Povratna polariteta Zaščita pred preobremenitvijo
Odzivni čas na izhodu	<= 10 ms Analogni izhod <= 5 ms Diskretni izhod
Switching output time delay	0 do 50 s V korakih po 1 sekundo
Tip zaslona	4 številke 7 segmentov
Lokalno signaliziranje	ZaLuč je vžgana ko je stikalo aktivirano 1 LED (Rumena)
Tip odzivnega časa prikaza	Hitro 50 ms Normalno 200 ms Počasen 600 ms
Prednost maksimalne zamude	300 Ms
Overall accuracy	<= 1 % merjenega obsega
Linearity error on analogue output	<= 0,5 % merjenega obsega
Hysteresis on analogue output	<= 0,2 % merjenega obsega
Merilna natančnost pri stikalnem izhodu	<= 0,6 % merjenega obsega
Natančnost ponovitve	<= 0,2 % merjenega obsega
Drift of the sensitivity	+/- 0,03 % merjenega obsega/°C
Drift of the zero point	+/- 0,1 % merjenega obsega/°C
Natančnost zaslona	<= 1 % merjenega obsega
Mehanska vzdržljivost	10000000 Ciklov
Globina	42 Mm
Višina	93 Mm
Širina	41 Mm
Teža izdelka	0,19 Kg
[Uimp] Nazivna napetostna trdnost ob impulzu	0,5 KV DC
Elektromagnetna združljivost	Susceptibilnost na elektromagnetno sevanje: 10 V/m 80 do 2000 MHz v skladu s/zEN/IEC 61000-4-3 Odpornost na konduktivne RF motnje: 10 V 0,15 do 80 MHz v skladu s/zSIST EN/IEC 61000-4-6 Preizkus odpornosti na prenapetost: 1 kV v skladu s/zEN/IEC 61000-4-5 Electrical fast transient/burst immunity test: 2 kV v skladu s/zEN/IEC 61000-4-4 Test odpornosti na elektrostatska razelektritev: 8 kV zrak, 4 kV kontakt v skladu s/zEN/IEC 61000-4-2

Okolje

Označevanje	CE
Certifikati izdelkov	CULus EAC
Standardi	EN/IEC 61326-2-3 UL 61010-1
Temperatura okoliškega zraka za delovanje	-20...80 °C
Temperatura okoliškega zraka za skladiščenje	-40...80 °C
IP stopnja zaščite	IP65v skladu zEN/IEC 60529 IP67v skladu zEN/IEC 60529
Odpornost proti vibracijam	20 gn 10...2000 Hz)EN/IEC 60068-2-6
Odporno proti udarcu	50 gn EN/IEC 60068-2-27

Embalážna enota

Unit Type of Package 1	PCE
Number of Units in Package 1	1
Package 1 Height	6,5 Cm
Package 1 Width	7,5 Cm
Package 1 Length	13,0 Cm
Package 1 Weight	184,0 G
Unit Type of Package 2	S02
Number of Units in Package 2	20
Package 2 Height	15,0 Cm
Package 2 Width	30,0 Cm

Package 2 Length	40,0 Cm
Package 2 Weight	4,02 Kg

Trajnost ponudbe

Uredba REACH	Izjava REACH
REACH, brez snovi SVHC	Da
Direktiva EU ROHS	Proaktivno zagotavljanje skladnosti (izdelek je zunaj področja uporabe direktive EU RoHS) Izjava EU RoHS
Brez živega srebra	Da
Informacije o izvzetju iz RoHS	Da

Dimensions

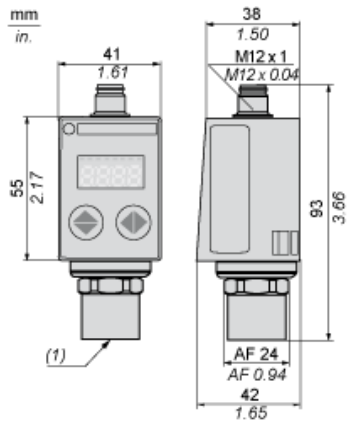

(1) Fluid entry: G 1/4 A female

Connections and Schema

Connector Wiring



(1) I Out or V Out

Analogue Output Description

Analogue Output Signal



X : Pressure

Y : Analogue output signal

(1) An offset of +/-5% of nominal pressure can be compensated (with Cof Configuration menu. Cof: Offset Compensation)

(2) The analogue curve can be adjusted from -25% to +25% of nominal pressure (with AEP Configuration menu. AEP: analogue end point).

Switching Output Description. Hysteresis Mode

The hysteresis switching mode is typically used for the "pumping and/or emptying applications".



X : Time

Y : Pressure

(1) Output

NP : Nominal Pressure

SP : Set point (adjustable from 8 % to 100 % NP)

rP : Reset point (adjustable from 5 % to 97 % NP)

Switching Output Description. Window Mode

The window switching mode is typically used for the "pressure regulation applications"



X : Time
 Y : Pressure
 (1) Output
 NP : Nominal pressure
 FH : High switching point (adjustable from 8 % to 100 % NP)
 FL : Low switching point (adjustable from 5 % to 97 % NP)

Switching Output Description. Time Delay

The Time Delay is typically used to filter out the fast pressure transients.
 The output only switches after a time "dS" and "dr" adjustable from 0 to 50 seconds.



X : Time
 Y : Pressure
 (1) Output
 SP : Set point
 rP : Reset point
 dS : Time delay on the set point
 dr : Time delay on the reset point